



Low-GWP Alternatives in Commercial Refrigeration: Propane, CO₂ and HFO Case Studies



Copyright © United Nations Environment Programme, 2014

This publication may be reproduced in whole or in part and in any form for educational or non-profit purposes without special permission from the copyright holder, provided acknowledgement of the source is made. The United Nations Environment Programme (UNEP) would appreciate receiving a copy of any publication that uses this publication as a source.

No use of this publication may be made for resale or for any other commercial purpose whatsoever without prior permission in writing from UNEP.

Disclaimer

The designations employed and the presentation of the material in this publication do not imply the expression of any opinion whatsoever on the part of the UNEP concerning the legal status of any country, territory, city or area or of its authorities, or concerning delimitation of its frontiers or boundaries. Moreover, the views expressed do not necessarily represent the decision or the stated policy of the UNEP, nor does citing of trade names or commercial processes constitute endorsement. While reasonable efforts have been made to ensure that the contents of this publication are factually correct and properly referenced, UNEP does not accept responsibility for the accuracy or completeness of the contents, and shall not be liable for any loss or damage that may be occasioned directly or indirectly through the use of, or reliance on, the contents of this publication.

Publication job number: DTI-1666PA

Acknowledgements

This document has been developed by the United Nations Environment Programme (UNEP) OzonAction Branch as part of UNEP's work programme under the Climate and Clean Air Coalition (CCAC).

This project was managed by the following UNEP OzonAction Branch team:

Shamila Nair-Bedouelle, Head
James S. Curlin, Network and Policy Manager
Ezra Clark, Programme Officer
Ruperto de Jesus, Capacity Building Assistant
Mugure Kibe, Documentation Assistant

This document was written by:

Walid Chakroun, *Department of Mechanical Engineering, College of Engineering and Petroleum, Kuwait University, and ASHRAE Director for Region at Large*

This document was reviewed by:

Alliance for Responsible Atmospheric Policy:

Dave Stirpe

Australia: **Annie Gabriel**

Canada: **Philippe Chemouny**

Environmental Investigation Agency: **Mark Roberts**

Institute for Governance & Sustainable Development:

Dennis Clare

US Environmental Protection Agency: **Nancy Akerman**

US Environmental Protection Agency: **Dave Godwin**

US Environmental Protection Agency: **Cindy Newberg**

US Department of State: **John Thompson**

UNEP would like to thank the CCAC HFC Steering Committee, the author, reviewers and the CCAC Secretariat for their guidance and contributions to this document.

Art direction and design by:

Sue Cowell, Atomo design

Aur lie Ek: design updates

INTRODUCTION

Low-GWP Alternatives in Commercial Refrigeration: Propane, CO₂ and HFO Case Studies

The Climate and Clean Air Coalition to Reduce Short-Lived Climate Pollutants (CCAC) is a unique global effort supporting fast actions to mitigate the impacts of short lived climate pollutants, such as black carbon, methane and many hydrofluorocarbons (HFCs) and addressing near-term climate change and air pollution at the same time. The CCAC is a voluntary partnership bringing together over 36 country and Regional Economic Integration Organization (REIO) partners and 44 non-state partners including intergovernmental organisations, representatives of civil society and the private sector.

The CCAC has launched a transformative initiative (entitled '*The HFC Initiative, Promoting HFC Alternative Technology and Standards*') for rapid implementation aimed at promoting HFC alternative technologies and standards to significantly reduce the projected growth in the use and emissions of high-global warming potential (GWP) HFCs in coming decades relative to business-as-usual scenarios. The objectives of the initiative are to mobilise efforts of the private sector, civil society, international organisations, and governments to:

- Promote the development, commercialisation, and adoption of climate-friendly alternatives to high-GWP HFCs;
- Encourage the uptake of climate-friendly alternatives that could support national, regional and global policies or approaches to reduce reliance on high-GWP HFCs;
- Overcome barriers that limit the widespread introduction of these climate friendly technologies, including those related to the establishment of standards; and
- Encourage the responsible management of existing equipment and better designs for future equipment in order to minimize leaks.

The HFC Initiative will help achieve these objectives by improving global understanding of current and projected future use of HFCs, by sharing lessons on the

design and implementation of policies to reduce their emissions and use, by addressing barriers, including reforming standards, and by validating climate-friendly technologies in key areas of HFC use or projected growth.

As countries phase out hydrochlorofluorocarbons (HCFCs) under the Montreal Protocol on Substances that Deplete the Ozone Layer, they often need to make choices between high-GWP HFC alternatives and, when available, more climate-friendly alternatives. Depending on the alternatives selected, the increase in HFC emissions could partly offset the climate benefits achieved by the earlier reduction in ozone-depleting substance (ODS) emissions under the Montreal Protocol.

The commercial refrigeration sector comprises the equipment, technologies and services used to store and dispense frozen and fresh foods at the appropriate temperatures. This sector includes stand-alone or self-contained systems, condensing unit systems, and centralised or 'multiplex rack' systems. According to the 2010 assessment of the Montreal Protocol advisory panel, the Technology and Economic Assessment Panel (TEAP) Technical Option Committee, these categories were estimated to contribute 7%, 47% , and 46% respectively to the total quantity (or 'refrigerant bank') of refrigerant used in 2006. Also the special report of the Intergovernmental Panel on Climate Change (IPCC)/TEAP¹ indicated that on a global basis, commercial refrigeration is the refrigeration subsector with the largest CO₂-equivalent emissions, representing 40% of total annual refrigerant emissions. These emissions are categorised as direct and indirect emissions. Direct emissions refer to emissions of the refrigerant itself during system manufacturing, operation, and disposal at end-of-life. Indirect emissions refer to the emission of carbon dioxide and other greenhouse gases (GHGs) that result from the energy consumption (usually electricity) of the system over its lifetime. Reducing the leakage rates through better design and installation practices will reduce the direct emissions. As reported by the IPCC, the refrigerant emissions might represent

⁴ Climate and Clean Air Coalition to Reduce Short-Lived Climate Pollutants Case Studies on Alternative Technologies in the Commercial Refrigeration Sector

¹ IPCC/TEAP Special Report: Safeguarding the Ozone Layer and the Global Climate System: Issues Related to Hydrofluorocarbons and Perfluorocarbons. 2005. Cambridge University Press, UK. pp 478

60% of the total emissions of GHGs resulting from system operation, the rest being indirect emissions generated by power production. A higher Coefficient of Performance (COP = heat removed/ required work) for the refrigerated system will help in reducing the indirect emissions since the amount of work required to remove the heat will decrease.

In order to assist in planning and implementing ODS transitions that minimise climate impacts, the CCAC has developed this booklet of case studies on low-GWP energy-efficient technologies that have been adopted in the commercial refrigeration sector as alternatives to replace or avoid high-GWP HFCs. Given that the commercial refrigeration sector has a number of climate-friendly refrigerant alternatives that are already commercialised or near commercialisation in some countries and regions, the booklet presents lessons learned from real cases in commercial refrigeration and aims to stimulate further investigation to enable a smooth transition away from high-GWP refrigerants and assist in the selection of future refrigerants. The case studies offer information for system purchasers and operators to consider when upgrading or replacing existing equipment with newly designed systems that decrease impacts on the ozone layer and climate change. Even though the majority of cases are from industrialised (Non-Article 5) countries, the information and experiences presented are relevant to all countries to help users, technical managers, and equipment suppliers in their assessments and understanding of these technologies in order to achieve similar success. The issues discussed in the case studies are primarily related to transitioning to climate-friendly refrigerants. These examples from end-users can help build confidence in, and illuminate pathways toward, more climate-friendly commercial refrigeration.

Research was conducted to generate a list of potential case studies for consideration taking into account all of the currently available zero- and low-GWP refrigerants in commercial refrigeration applications, including “natural” refrigerants, such as hydrocarbons, carbon

dioxide (CO₂), and ammonia, as well as the other major category of alternatives comprising man-made chemicals such as the unsaturated HFCs known as hydrofluoroolefins (HFOs). HFOs are a new class of unsaturated HFC refrigerants which have lower GWPs and shorter atmospheric lifetimes when compared to other HFCs. Some criteria such as geographic location, refrigerant used and available information of the proposed applications were taken into consideration when selecting the case studies. These chosen case studies take into account energy efficiency benefits of alternatives, as well as cost, safety, availability, and other environmental considerations. Robust technical information was collected in the chosen case studies based on data provided by the source. An overview of the refrigeration cycles that are used in supermarkets is provided below.

The case studies that are covered in this booklet address mainly centralised systems used in supermarket stores, as well as stand-alone units. Case studies from other sectors, such as condensing units, are also important areas that could be addressed in future work. The technologies presented in these case studies are only some examples of the many available options for zero- and low- GWP substances, taking into account all design criteria, such as system performance, environmental impact, and cost analysis. The cases presented here focus on CO₂, hydrocarbons and unsaturated HFC refrigerants, however other options exist which deploy ammonia and other configurations of refrigerants. All these refrigerants still have many challenges that should be considered in the design such as their flammability, toxicity, lower efficiencies in some cases, and cost. Balancing the safety, energy efficiency, cost, and environmental impact of refrigerants using a consistent and comprehensive methodology across all refrigerants and system types is essential in assessing alternatives. Good design is also important for reducing refrigerant emissions and preventing refrigerant loss during installation, operation, maintenance,

decommissioning and end-of-life disposal. There are also several ways to reduce the refrigerant charge in a supermarket, such as proper piping design, type of condenser used, use of electronic expansion valves, and an efficiently designed distributed system. All these are measures to reduce refrigerant charges and therefore decrease the overall CO₂ footprint of the system.

Types of Commercial Refrigeration Systems

Most supermarkets use centralised direct expansion (DX) systems to chill their products. Typically, these refrigeration systems are charged with 1,360 – 1,815kg of refrigerant and can leak in excess of twenty percent of their charge each year. Commonly used refrigerants include ozone-depleting HCFC refrigerants, often HCFC-22, and blends consisting entirely or primarily of HFCs. Both HCFCs and HFCs are potent greenhouse gases. Fortunately, in recent years there have been advances in refrigeration technology that can help food retailers reduce both refrigerant charges and refrigerant emissions. Below is a general description of a centralised DX system as well as an overview of the different advanced refrigeration options.

- Centralised DX System
- Distributed System
- Secondary Loop System
- Transcritical CO₂ system
- Cascade System

Centralised Direct Expansion System

A large number of supermarkets use centralised DX systems to cool their display cases and walk-in refrigerators. In a DX system, the compressors are mounted together and share suction and discharge refrigeration lines that run throughout the store, feeding refrigerant to the cases and coolers. The compressors are located in a separate machine room, either in the back of the store or on its roof, to reduce noise and prevent customer access, while the condensers are usually air-cooled and therefore placed outside to reject heat.

The multiple compressor racks operate at various suction pressures to support display cases operating at different temperatures. The hot gas from the compressors is piped to the condenser and converted to liquid. The liquid refrigerant is then piped to the receiver and distributed to the cases and coolers by the liquid manifold. After cycling through the cases, the refrigerant returns to the suction manifold and the compressors. Supermarkets tend to have one DX system for low-temperature refrigeration (e.g., ice cream, frozen

Schematic of a Centralised DX System

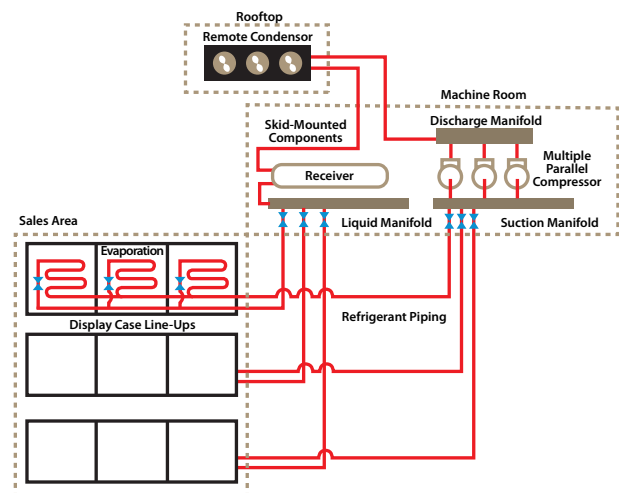

Source: International Energy Agency (IEA), 2003. "IEA Annex 26: Advanced Supermarket Refrigeration/Heat Recovery Systems, Final Report Volume 1-Executive Summary"

foods, etc.) and one or two DX systems for medium temperature refrigeration (e.g., meat, prepared foods, dairy, refrigerated drinks, etc.).

Distributed System

Unlike centralised direct expansion refrigeration systems, distributed systems use multiple smaller units that are located close to the display cases that they serve. For instance, compressors in a distributed system may be located on the roof above the cases, behind a

nearby wall, or even on top of, or next to, the case in the sales area. The close proximity of the compressors to the cases and coolers allows the system to use less piping and a smaller refrigerant charge than traditional DX systems. This reduction in charge often results in a decrease in total refrigerant emissions.

Secondary Loop System

Secondary loop systems use a much smaller refrigerant

Schematic of a Distributed System

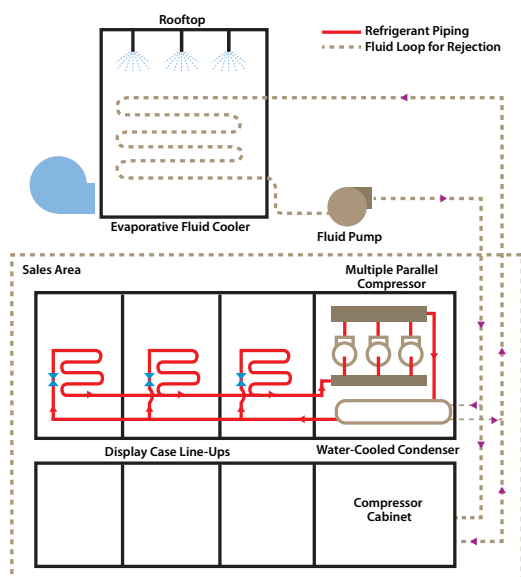

Source: International Energy Agency (IEA). 2003. "IEA Annex 26: Advanced Supermarket Refrigeration/Heat Recovery Systems, Final Report Volume 1-Executive Summary."

Schematic of a Secondary Loop System

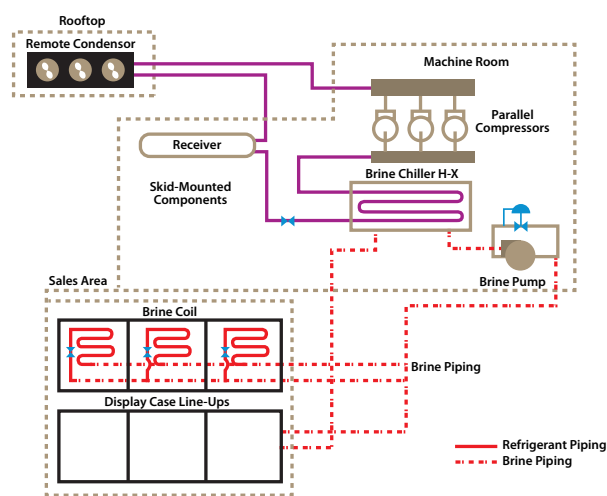

Source: Southern California Edison and Foster-Miller, Inc. 2004. "Investigation of Secondary Loop Supermarket Refrigeration Systems." Report prepared for California Energy Commission, Public Interest Energy Research Program.

charge than traditional direct expansion refrigeration systems, and hence have significantly decreased total refrigerant emissions. In secondary loop systems, two liquids are used: a primary refrigerant and a secondary fluid. The secondary fluid is cooled by the primary refrigerant in the machine room and then pumped throughout the store to remove heat from the display equipment. Secondary loop systems typically operate with two to four chiller systems depending on the temperatures needed for the display cases.

Transcritical CO₂ system

Refrigeration systems that use CO₂ as a primary refrigerant are commonly referred to as transcritical CO₂ systems. In transcritical CO₂ refrigeration systems CO₂ is the sole refrigerant, evaporating in the subcritical region and rejecting heat at temperatures above the critical point in a gas cooler instead of a condenser. In addition to having a simple concept, this system has considerable environmental benefits in terms of reducing HFC usage completely.

Cascade System

Cascade systems consist of two independent refrigeration systems that share a common cascade heat exchanger. Each of the two systems uses a different refrigerant that is most suitable for a specific temperature range. High temperature systems use high boiling point refrigerants such as R-404a, R-507a, R-134a, propane, butane, and ammonia, whereas low

temperature systems use low boiling refrigerants such as R-744 (CO₂) and R-508B. The advantages of a cascade system include a reduction in the refrigerant charge and a reduced carbon footprint.

Disclaimer

Inclusion of these case studies is not an endorsement of the companies or products by UNEP or the CCAC. The information presented in these case studies was provided by the companies involved. The content and figures presented in the case studies are the responsibility of these companies and has not been verified by the CCAC or UNEP. The booklet contains links to various websites; CCAC/UNEP is not responsible for the content of these sites.



As countries phase out hydrochlorofluorocarbons (HCFCs) under the Montreal Protocol they often need to make choices between high-GWP hydrofluorocarbon (HFC) alternatives and, when available, more climate-friendly alternatives

CASE STUDY

CarrefourSA Express Kurtköy Commercial Refrigeration

Name of the Store/facility:

CarrefourSA Express Kurtköy

Location:

Kurtköy, Turkey

Contact information:

Jean-Michel Fleury, Jean-Michel_Fleury@carrefour.com

Type of Facility:

Hypermarket, Store Area =765 m²,
Food & Department Store.

Technology Transition:

Transition from High-GWP refrigerant R-404A to CO₂.

Project Background:

As part the Carrefour Group's effort to mitigate climate change by reducing HFC refrigerant charge and refrigerant leakage, the Group has set a goal to phase out HCFCs in new refrigeration equipment by 2015. Currently Carrefour is progressively rolling out full CO₂ systems, having installed its first CO₂ transcritical refrigeration system in Istanbul, Turkey, at the Kurtköy-Millennium Carrefour Express. Fig. 1 shows photo of the store in Kurtköy, which has a sales area of 765 m². The retrofitted refrigeration system in the Turkish Kurtköy store entered into operation on 9 May 2012, and is one of four sites operated by the retailer that use 100% natural refrigerants.

In more than 30 stores across Europe, Carrefour was already using a hybrid solution such as a cascade system, which combines synthetic refrigerants and CO₂, but the change-over to an installation that operates solely with CO₂ marked a clear shift to natural refrigerants. Carrefour plans to continue to set up new stores across Europe using natural refrigerants.

"Carrefour states that the market penetration of CO₂ commercial refrigeration could be further accelerated if qualified contractors were more widely available to cater for the needs of the booming CO₂ refrigeration market. This is relevant for countries outside the European market and more particularly in Asia and Latin America."— **Jean-Michel Fleury, Director of Assets Carrefour Group.**



Fig. 1 The CarrefourSA Express Kurtköy, Turkey

New System/Installation:

Food refrigeration accounts for two-thirds of the Carrefour Group's greenhouse gas emissions. The emissions arise from refrigerant leaks, as well as from electricity consumed by refrigeration equipment. To reduce these emissions, Carrefour Turkey is piloting a highly innovative solution - using the natural fluid CO₂ for both refrigerators and freezers at the Kurtköy store. The technology used in Turkey is new to that part of the world, and is only the fourth time it has been used by the Carrefour Group. CO₂ is being used as the alternative to the original HFC refrigerant R-404A. R-404A, with a GWP of 3,922, is an HFC refrigerant, a colorless, odourless mixture which is used as a replacement for R-22, a refrigerant which is being phased out under the Montreal Protocol.

The new Kurtköy's CO₂ installation has the following dimensions:

There are 13 showcases for positive temperature products, and two for negative temperature products, which equates to 33 meters of refrigeration displays. Compressor racks are used to provide cooling for these showcases at negative and positive temperatures. The capacity of the positive rack compressors is 40 kW, and negative rack compressors 4 kW.

The technical specifications for the compressor racks include:

The compressor rack for medium temperature applications is composed of four Bitzer compressors with a total refrigeration capacity of 67.44 kW, and a coefficient of performance (COP) of 1.12. This COP

is during the summer when the gas cooler outlet temperature is 45° C, while in winter time the COP is 6.99. The compressor rack for the low temperature side is composed of one Bitzer compressor with a total refrigeration capacity of 4.80 kW, with a COP of 4.58. Fig. 2 shows a photo of the five-compressor rack.

The design using CO₂ is similar to a typical transcritical system. Since the pressure level is higher than 70 bar the piping design requires the use of steel pipes throughout. A transcritical CO₂ system operates in transcritical mode whenever the refrigerant is above 31° C. The condenser becomes a gas cooler at



Fig. 2 The CO₂ compressor rack

temperatures above 31° C and the CO₂ leaving the evaporator is supercritical, a state where vapour cannot condense and one cannot distinguish liquid from vapour.

Where the pressure level is less than 45 bar, the design is like that for any traditional refrigerant.

The system also has a solution for decreasing the ambient temperature by using the ChillBooster™ adiabatic air cooling system. The ChillBooster™ is manufactured by CREA (Italy).

Fig. 3 is a schematic for the ChillBooster™ system used for high ambient conditions. The system works on cooling the air to a lower temperature going over the coils by evaporative cooling. ChillBooster™ atomises water into very fine droplets that evaporate spontaneously, cooling the air. The coil is thus cooled by

a flow of colder air and droplets of water, allowing more favourable operating conditions and thus increasing the cooling capacity of the system.

ChillBooster™ can be used as an extra cooling step only on high temperature days. The droplets of water are evaporated by absorbing heat from the air and, as a consequence, it can decrease the air inlet temperature by up to 15° C to help the system run in optimal conditions (see Fig. 3). This system works best in dry climates, but it is still possible to give reasonable results in higher humidity areas. The system works everywhere except in areas that have both a high temperature and high moisture content simultaneously.

Schematic of the ChillBooster™ System



Fig. 3 Schematic for the ChillBooster™ showing how the high ambient temperature air is cooled by water droplets before passing over the coil.

Performance:

The system has been operating in Kurtköy, Turkey where the annual average temperature varies from 0.5° C to 25.7° C. In only 12 months of operation, the technology has significantly reduced the environmental impact of the store. The CO₂ used in the refrigeration system is around 3,922 times less potent in terms of global warming potential than the refrigerant (R-404A) previously used at Kurtköy.

The quantity of CO₂ needed for the refrigeration units is approximately one-third less than the refrigerant charge required by a conventional system.

The performance of the CO₂ system is compared to similar cooling capacity systems operated in roughly similar climatic conditions using R-404A.

The quality of the pipe fittings has been improved and as a result, refrigerant leaks are expected to be reduced by 75%.

The CO₂ solution improves the energy efficiency of the refrigeration units by around 15%, which equally limits CO₂ emissions resulting from electricity consumption.

Advantages of this CO₂ System

- High-GWP refrigerants (which can be a direct contributor to global warming when leaked to the atmosphere) are reduced.
- Total elimination of HFCs from the system.
- High Volumetric capacity - The system can absorb much more heat than an HFC-based system, resulting in reduced compressor and pipe size for the same

cooling effect.

- Low HFC refrigerant charge for subcritical systems
- Lower than HFC Refrigerant Costs - CO₂ costs are currently 90% less expensive than traditional refrigerants (US\$2.2/kg versus US\$24.2/kg for R-404A).
- Reduced Carbon Footprint - CO₂ has a GWP of 1 vs. HFC which has a GWP of 3,922 for R-404A.
- Reduced Carbon Emissions - Because the refrigerant is confined to a machine room, there are fewer braze joints and a significant reduction in potential for leaks in the system.

Disadvantages of transcritical CO₂ System

- Higher investment cost (the components capable of being operated safely in such high pressure applications can be more expensive).
- The COP of the system is reduced when operated in higher ambient conditions.
- CO₂ is heavier than air - importance of good ventilation in case of leakages
- Limited local expertise for service and maintenance in Istanbul. The flash gas leakage causes formation of dry ice on the system.
- Compressor range is very limited (but increasing).
- Difficult to obtain components at present.

Some of these disadvantages can be overcome with time when systems become more prevalent and through improved training of technicians.

Cost and Economic Considerations:

In addition to its excellent technical performance, the CO₂ transcritical installation also offers very significant economic benefits. The Kurtköy hypermarket should not only reduce its overall annual energy bills by 7%, but it should also be able to reduce the amount spent on refrigerants, which is crucially important given that the price of synthetic gas is increasing.

Disclaimer

The information presented here is provided by Carrefour. The accuracy of the content and figures is the responsibility of the company and these have not been verified by the CCAC or UNEP.

CASE STUDY

Sobeys Commercial Refrigeration

Name of the Store/facility:

Sobeys, IGA Cookshire

Location:

35 rue Principale Est, Cookshire, Québec J0B1M0, Canada

Contact information:

Rod Peterson, National Procurement Manager,
Rod.Peterson@sobeys.com

David Smith, VP of Sustainability,
David.Smith@sobeys.com

Type of Facility:

Supermarket, Store Area = 1,950 m², Grocery and Food Retailer, Store has LEED certification.

Refrigerant Used:

CO₂, transcritical refrigerant systems

Project Background:

Sobeys owns or franchises more than 1,300 stores all across Canada under different retail banners. In the province of Quebec, Sobeys operates under the IGA brand. In February 2010, the new IGA Cookshire store opened. The new supermarket is a state-of-the-art one, having been built to LEED (Leadership in Energy and Environmental Design) specification with environmental considerations throughout the building. Fig. 1 shows a photo of the Sobeys store. Amongst the environmental features of this 1,950 m² supermarket are improved air quality, such as low VOC (Volatile Organic Compound) finishes and natural ventilation. Moreover, the transcritical CO₂ refrigeration system reduced a large amount of greenhouse gas emissions relative to traditional systems used in other Sobeys stores.

The Carnot Refrigeration Company was retained by Sobeys in order to develop an alternative to the conventional refrigeration systems available on the market, which were less efficient, and incurred high maintenance costs. The goal was to provide a sustainable and reliable solution that would have lower initial (equipment and installation) and operating (energy, maintenance, gas replacement, insurance) costs. After many internal discussions, the management



Fig. 1 Photo of the Sobeys, IGA Cookshire in Quebec, Canada

concluded that there were substantial benefits to eliminating HCFCs completely and focusing on a full transcritical CO₂ refrigeration system. Furthermore, in 2010, Sobeys endorsed the Consumer Goods Forum's natural refrigeration initiative (<http://www.theconsumergoodsforum.com/sustainability.aspx>), which encourages members to phase out HFC refrigerants in all new builds from 2015.

Sobeys' Quebec division piloted the approach to natural refrigerant systems. It had already installed low GWP transcritical CO₂ systems when in 2009 a national initiative was undertaken to review alternatives to traditional HCFC refrigerant systems, with a particular focus on various CO₂ systems. Several CO₂ options were considered, including the following:

- Secondary Loop Medium Temp (MT) Glycol and Low Temp (LT) CO₂ liquid
- Secondary Loop MT Glycol and LT Cascade CO₂
- Secondary Loop MT CO₂ liquid and LT CO₂
- Secondary Loop MT CO₂ liquid and LT Cascade CO₂
- Transcritical CO₂ DX.

"Sobeys' transcritical refrigeration system design is the solution for our climate here. It is meeting our entire vision." — **Simon Bérubé**, senior director of engineering and commercial development, Sobeys Quebec.

New System/Installation:

The transcritical CO₂ refrigerant system, which has become the new national standard for refrigerant systems at Sobeys, is a low GWP (Global Warming Potential) transcritical CO₂ system. It will be included in all new builds and will be considered for retrofits where feasible based on the store size and scope of the retrofit. Within these systems CO₂ levels are monitored for leakage; however, because CO₂ is a natural gas, these systems do not pose the same risk to the environment (due to leakage) as traditional HFC systems.

The average Sobeys supermarket refrigeration system contains 1,130-1,360 kg of HCFC refrigerant R-22. HCFC refrigerants have an ODP above zero and also significant GWPs of 1,810-4,657 and are therefore responsible for a significant portion of a typical supermarket's direct carbon footprint due to leakages. The common HFC replacement option for R-22 is R-507 or R-404A. Refrigerant R-507 has a GWP of 3,985, where a 1 kg leak of R-507 is equivalent to 3,985 kg of CO₂ emissions. Average rates of leakage of these refrigerants are between 10% and 30% per store each year, and almost 30% of Sobeys' stores' aggregate carbon footprint.

The transcritical CO₂ refrigerant system shown in Fig. 2 uses only CO₂, which has a GWP defined to be 1, as compared to the higher GWP of R-507. The CO₂ systems are energy efficient in comparison with traditional refrigeration systems, and especially with the combination of heat reclaim introduced with them, provide a net reduction in store energy consumption. The intensive reclaiming of waste heat from the refrigeration units can be used to cover almost all the heating needs of the supermarket. A pre-heating water loop is also installed in the supermarket to preheat hot water used within the store.

Fig. 3 is a schematic diagram and process explanation of the Carnot Refrigeration Transcritical CO₂ system used at Sobeys.



Fig. 2 Photos of the transcritical CO₂ system at Sobeys designed by Carnot Refrigeration.



Challenges

One of the initial challenges and concerns when installing these systems was that of contractor training and timely access to new components. It was unclear if contractors would be familiar enough to service and work with these systems. This was a particular concern as Sobeys considered scaling up and extending new builds into stores far from the Quebec location of the CO₂ system manufacturer where direct support from the system manufacturer would be much less readily available than during the Quebec pilot phase. However contractors were found to be increasingly embracing this technology and investing in servicing and installation training as these systems become more common. Another challenge was building the company's plan for the transition to transcritical CO₂ because of the differences in geographical and infrastructural constraints between stores. Furthermore, there are also financial challenges. At this stage, as early adopters, the Sobeys systems are still fairly expensive in capital cost terms compared to future projections, thus the return on investment (ROI) is dependent on the size and nature of the store, whether heat reclaim is already in place, and sometimes whether

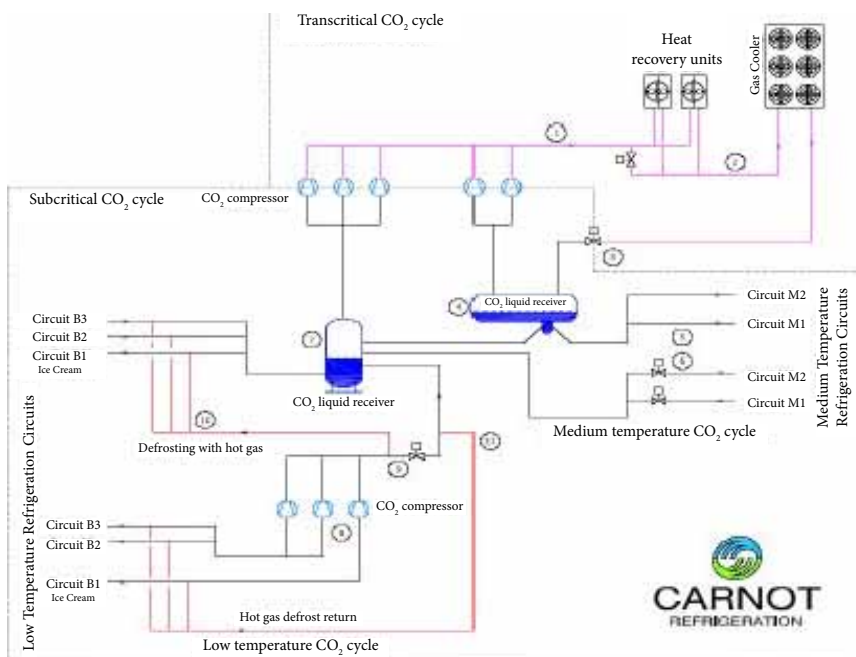

Fig. 3 Diagram explanation of the Carnot Refrigeration Transcritical CO₂ system

government incentives exist. These systems at Sobeys have a 3-4 year average return on investment. However, as mentioned above, the company expects costs to decrease and installation and infrastructural support to become easier as these systems become more prevalent and efficient. This presents the opportunity to reduce the cost curve.

Emerging out of these challenges and the commitment to this system, many lessons have been learned. For example, in order for the company's contractors and suppliers to provide the services needed for a new system, they need to be engaged early in the overall process from designing the system through the procurement and installation stages. They need to also understand the advantage of such a system in order for them to develop expertise on these new refrigeration systems, as it does require investment in training and adds complexity to their businesses. It is also important to look ahead, when conducting a business case study on return on investment (ROI), because what may not be feasible today may very well be feasible in the near future as regulations and industry initiatives drive adoption of these systems. Cost forecasts for

refrigerant re-charges and energy savings are important considerations in such cases.

Performance:

Sobeys has made a commitment to alternative CO₂ refrigeration technology and is very pleased with the results. The installation of these transcritical CO₂ refrigerant systems with heat reclamation has not only made financial sense, but clearly makes environmental sense and is in line with Sobeys' commitment to reducing its CO₂ footprint and impact. The approach taken to come up with performance indicators was applied equally to all stores of identical nature. Therefore, the results will be reported per store. The following are the calculated reductions in comparison to a traditional HCFC refrigerant system:

- Carbon dioxide emissions reduced by 62% = 861,920 kg CO₂-equivalent per year, per store
- Energy consumption reduced per year by 15% -18%
- Natural gas (heating) consumption reduced per year by 75% - 85%

Note that Sobeys experience with the performance of transcritical CO₂ systems is based on all of their stores being located in temperate climates (annual average temperature 0° C to 20° C) in the Northern Hemisphere. Stores located in higher ambient temperature zones would have different design parameters and operating conditions, and therefore these reductions in CO₂ emission and in energy consumption will vary.

Cost and Economic Considerations:

The initial capital costs of a transcritical CO₂ system are more than traditional HCFC DX systems (approximately 11% increase in capital for refrigeration equipment), however operating costs and energy savings will offset the initial capital cost. The simple payback on a transcritical CO₂ system with heat reclaim is less than three years.

Cost savings are a result of lower maintenance (including significantly reduced refrigerant re-charge costs) and energy costs. While it is financially viable to move forward to implement such projects today, Sobeys is proceeding with this technology knowing that the initial capital costs will be rapidly reduced through design, manufacturing and installation efficiencies, and as the Montreal Protocol deadlines for HCFC phase-out approach these systems will become more prevalent and standardised throughout the supply chain.

The following simplified annual financial analysis of a single supermarket assumes that heat reclaim is included as a standard feature, as it helps to drive the reduction in operating costs. Moreover, it is generalised

across Canada, where heat, energy, refrigerant, installation and maintenance costs may vary.

Total incremental capital cost for the refrigeration system increased by 11%.

Total installation costs reduced by 0% to 15%.

Maintenance costs reduced by 50% (as experienced across stores in Sobeys Quebec, this would be the average annual refrigeration maintenance costs of a typical IGA store). A large part of the cost reduction would be replacement refrigerant gas from leaks.

Heating cost reduced by 75% to 85%.

Simple payback within three years.

Fig. 2 and 3 are courtesy of Carnot Refrigeration. Fig. 1 is courtesy of www.voirvert.ca

Disclaimer

The information presented here is provided by Sobeys. The accuracy of the content and figures is the responsibility of the company and these have not been verified by the CCAC or UNEP.

CASE STUDY

Verdemar Commercial Refrigeration

Name of the Store/facility:

Supermercado Verdemar – Nova Lima Store

Location:

Belo Horizonte, Brazil

Contact information:

Carlos Arruda – marketing@superverdemar.com.br

Type of Facility:

Gourmet supermarket, Store Area =1,800 m²,
Small chain fine food and wine retailer.

Refrigerant Used:

CO₂ cascade system with HFC (R-134a) refrigerant as the high side fluid. The new installation uses a cascade system composed of a twin primary system using 75 kg of R-134a (GWP=1430), and a secondary system using 100 kg of CO₂

Project Background:

The Supermercado Verdemar – Nova Lima Store was opened in 2010, at Nova Lima, Brazil, 10 kilometers from Belo Horizonte, at an altitude of 1,350 meters above sea level. The building has 1,800 m² of store floor and 500 m² of kitchens and cold chambers. Fig.1 shows a photo of the external view of the store.



Fig.1 Photo of Supermercado Verdemar - Nova Lima Store

Alexandre Poni, Executive Director of supermarket chain Verdemar highlighted the leading role that company executives must take in driving sustainability to the retail sector, during his presentation in a conference “Sustainability as a competitive advantage” held in São



Fig.2 Photo of the store's refrigerated showcases

Paulo. Towards that vision, Verdemar adopted a CO₂ cascade system after undertaking studies on energy efficiency, environmental impact, installation cost reduction and maintenance cost optimisation.

After two years of research the final project design and installation took 30 days and 60 days, respectively. The main challenges were importing special high technology parts and components and ensuring that the relevant personnel were properly trained to operate the system. Fig. 2 shows a photo of refrigerated cases inside the store.

New System/Installation:

The approach is to use CO₂ as one of the fluids in a cascade system along with an HFC refrigerant (R-134a) as the high temperature fluid. R-134a, is an HFC haloalkane refrigerant with GWP of 1,430. Such systems may have a much lower HFC refrigerant charge, and the global warming potential is reduced compared to a baseline system using only HFC refrigerant.

TECHNICAL DATA:

- Cascade system built inside a large rack that holds most of the working components.
- The Primary dual circuit system is based on R-134a with a load of 136 kg of gas, industrially mounted and piped inside the cooling unit rack in the main rack, using a small volume of gas. This system has zero history of leaks and approximately one-third the amount of GWP as compared to a system using only R-404A or R-507.

- The Secondary system is based on R-744 (CO₂), developed with special high technology parts and components, working on Direct Expansion (DX) or in liquid fluid subsystems.
- The CO₂ subcritical scheme was specially fine-tuned by lowering the condensing temperature of the R-134a primary system to 40° C and raising the evaporation temperature to -8° C, resulting in 71% less energy consumption with a payback period of 19 months. This is achieved by a special patented adiabatic cooling system at the primary condensation circuit allowing a very efficient heat exchange.
- The use of Electronic Expansion Valves were mandatory for better control of the large expansion capacity of CO₂ and to prevent return of liquid to the compressor, as well as keeping stable temperatures at refrigerated points, shorter response time to changes, shorter operation of compressors and lower power consumption.
- Low cost, low power iQ motors (70% energy savings) at the secondary liquid fluid systems, with special larger area evaporators developed by Arneg. The savings are compared to traditional DX HCFC showcases used in the past. It is important to mention that this solution avoids the need for defrosting, hence additional energy savings is achieved.
- High efficiency, progressively activated fans at the condenser, with Electronically Controlled (EC) variable speed DC motors; working on a high-efficiency moist hives adiabatic cooling system, patented by Plotter-Racks Brazilian contractors.
- High-efficiency fans with dual speed ESM² DC motors in evaporation grids, especially at the production sectors, with energy savings of 36% and a payback period of 14 months, and better ergonomic comfort work conditions.
- Frequency regulated pumps, with energy savings of 19% and a payback period of 21 months.
- Frequency regulated Bitzer compressors, with energy savings of 8% compared to conventional compressors without frequency regulation and a payback period of

23 months.

- Low condensing pressure (30 bar).

This profile installation was then deployed in the two stores opened in 2010 and 2011 and at the main Warehouse in 2012, and has since been adopted as a standard for the chain.

So far, the company operates on CO₂ in three out of its eight stores. There are also two new stores in 2013, and plans are in place to convert the older stores to CO₂.

AMBIENT CONDITIONS:

Maximum expected temperature: 38° C

Wet bulb temperature: 24° C

REFRIGERATION LINES CAPACITY:

Medium temperature (without condensation): 204 kW

Low temperature: 35 kW

MEDIUM TEMPERATURE SYSTEM

Medium temperature chiller with secondary fluid

Primary Fluid: R-134a

Secondary Fluid: Propylene Glycol

Evaporation temperature: -8° C

Maximum condensation temperature: + 40° C

Total unit capacity: 249 kW

LOW TEMPERATURE SYSTEM

Direct Expansion rack for frozen products

Primary fluid: R-134a

Secondary fluid: R-744 (CO₂)

Evaporation temperature: -29° C

Maximum condensation temperature: -4° C

Total unit capacity: 36 kW

Figures 3 and 4 show diagrams for the medium and low temperature systems respectively.

The main lesson learned was that, after personnel training and the construction of a good system with a solid design, the new installation became as easy

Medium temperature system diagram

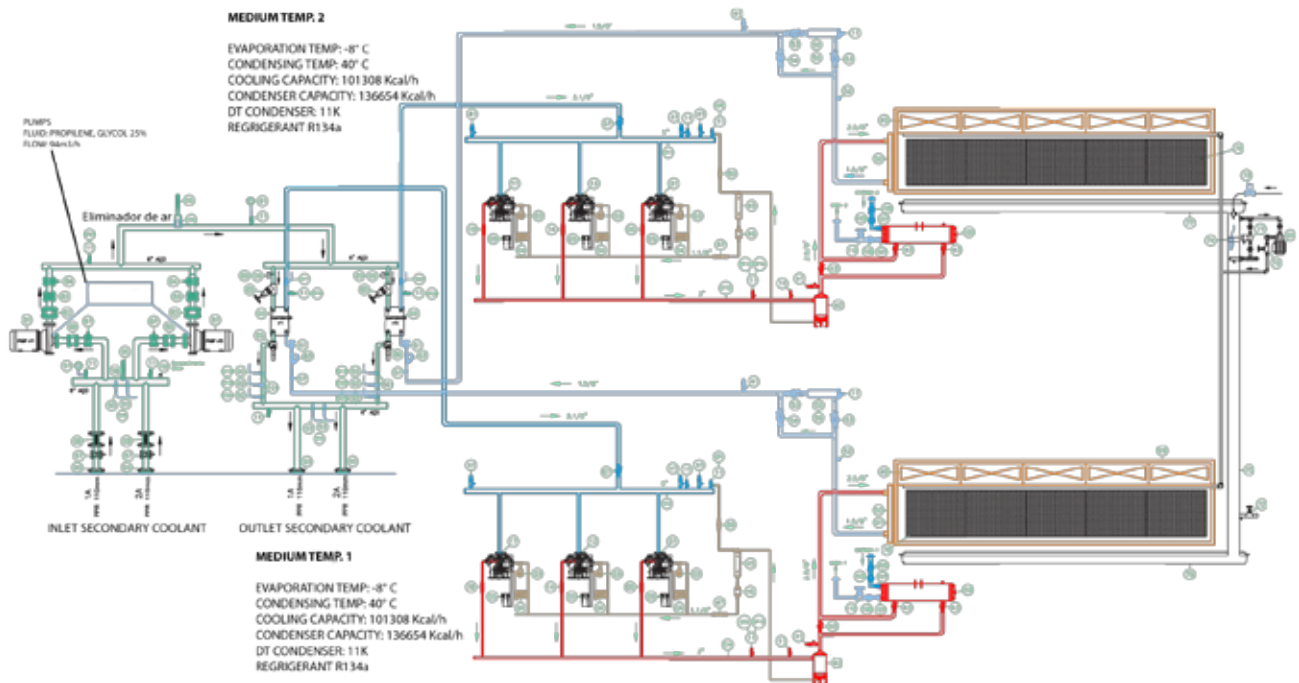

Fig.3 Medium temperature system diagram

Low temperature system diagram

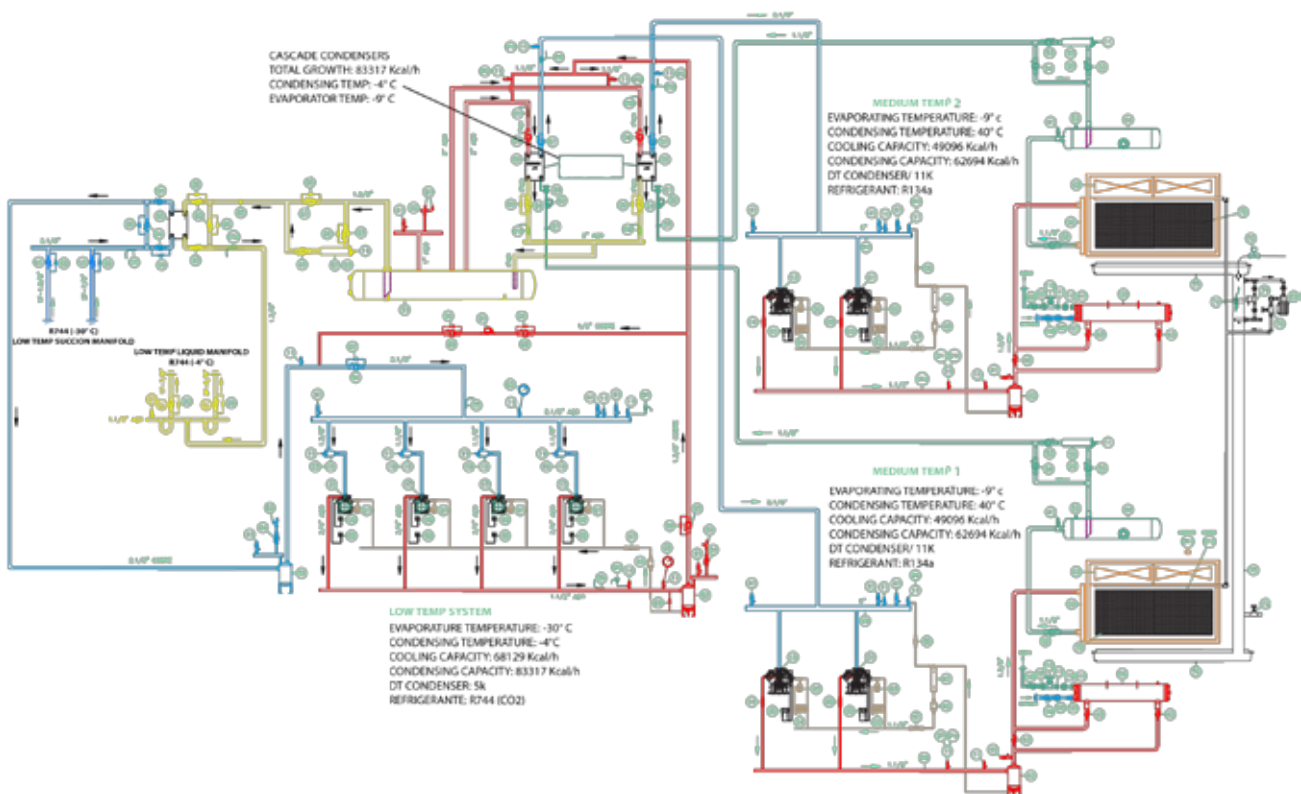

Fig.4 Low temperature system diagram

to maintain and operate as any other conventional refrigeration system.

Performance:

The overall achievement of this installation was a result of investment in training, equipment development and component research. The chosen components behaved as expected, allowing the optimal functioning of technologies to obtain the desired efficiency.

The resulting energy efficiency was 30% better, compared with the previous HCFC conventional systems. The main characteristics of the new CO₂ system are the adaptation of several high technology components in the global assembly such as:

- Intelligent two-speed ESM motors evaporation fans in refrigerated chambers and preparation areas, contributing also to a better ergonomic comfort.
- Progressively activated, variable speed EC motors in special aerodynamic designed ventilators in the condensing unit.
- iQ motors in liquid fluid evaporation grids, with very low energy consumption

The company acknowledges that at present while there is better availability of parts and components in the local market, facilitation of import of special parts and components from official authorities can be an important issue for the adoption of these new technologies. The main items required are R-744 compressors, intermediate heat exchangers, electronic valves and controllers. Fig. 5 shows a photo of the refrigeration system.

As R-744 is odourless, and its presence at levels greater than 10% is a serious health and safety issue, the company uses sensors and detectors in closed rooms and double release valves located in exterior locations as additional safety measures.

Cost and Economic Considerations:

Comparing the cost of the new system with conventional installations in the older stores, the company estimates



Fig. 5 The refrigeration system

a capital cost increase of 20%, taking into consideration the rack assembling, compressors, condensers, chillers, heat exchangers, evaporators, valves, piping, electric materials, command and control panels, hand work, start up and operation tests. However, this is offset by the reduced maintenance, operating and energy costs of the new system.

Comparison with older systems:

The payback of this system is less than 30 months.

The maintenance cost was reduced by 40%.

Energy savings are 30%.

One important aspect is that the energy reduction will be continuous, lowering costs and contributing to environmental benefits.

Disclaimer

The information presented here is provided by Supermercado Verdemar. The accuracy of the content and figures is the responsibility of the company and these have not been verified by the CCAC or UNEP.

“The new installation became as easy to maintain and operate as any other conventional refrigeration system.”

Verdemar Case Study



CASE STUDY

Waitrose Commercial Refrigeration

Name of the Store/facility:

Waitrose, Bromley South

Location:

Bromley, Kent, UK

Contact information:

Jim Burnett, jim_burnett@johnlewis.co.uk

Type of Facility:

Supermarket, Store Area =2,170 m², Groceries, Food. Waitrose Limited is an upmarket chain of British supermarkets, forming the food retail division of Britain's largest employee-owned retailer.

Refrigerant Used:

Honeywell Solstice™ ze, R-1234ze, HFO-1234ze. This case study has the world's first HFO chillers.

Project Background:

Bromley is near London and the store has a 2,170 m² sales area. The Bromley South store was opened in November 1996 and the plant was typical of systems built around that time. The existing system was R-404A and did not comply with the Waitrose policy of HFC reduction. Waitrose has signed on to the Consumer Goods Forums Resolution to start phasing out HFC refrigeration systems from 2015. Fig. 1 shows a photo of the store.

The new system is composed of two air-cooled HFO machines, each rated at 180 kW, which provide chilled water as a condensing medium for the in-store integral cases which run on propane. Waitrose is carrying out energy assessments on the chillers in the Bromley store to establish how they perform in relation to comparable chillers running on hydrocarbons. If the trial is successful as anticipated, Waitrose plans to adopt the HFO solution as part of its refrigeration platform for future stores.

Ambient conditions are typical of that around the UK and close proximity to London where the winter temperatures seldom fall below -4° C or rise above 14° C and the summer average temperature is 24° C.

The chilled water project was carried out in 2011 whereby the existing compressor refrigeration packs



Fig. 1 Photo of the Waitrose store, Bromley South

were made redundant and the chilled water system installed.

Waitrose had decided on a water-cooled refrigeration system as these both reduced the refrigerant charges in the branch (as each cabinet is integral) and the potential for leakage due to water being at a lower pressure and systems being of a small individual charge.

Jim Burnett of Waitrose said: "We believe the HFO solution shows great promise, as it combines good efficiency with very low global warming potential. This is obviously a highly desirable profile in a refrigerant. If the ongoing monitoring of energy continues to prove successful, we plan to include HFO-based chillers in our choice of refrigeration platforms for stores in the future".

New System/Installation:

1,3,3,3-Tetrafluoropropene (HFO-1234ze) is a hydrofluoroolefin. Solstice™ ze is a fluorinated gas from the HFO family that was developed as a "fourth generation" refrigerant to replace R-134a and other HFCs with high GWPs. HFO-1234ze has zero ozone-depletion potential and a low global-warming potential (GWP = 6).

Component selection information was very limited due to the pioneering use of this new refrigerant; reciprocating compressors were the only option at the time of installation.

The system is believed to be the world's first supermarket installation of a packaged chiller using an HFO refrigerant. The Italian-made Geoclimachillers are based on Frascold reciprocating compressors and operate on refrigerant HFO R-1234ze from Honeywell.

Fig. 2 shows schematics for the installed compressors. Its specifications are provided in Table 1. The total cooling capacity of the chillers was 360 kW with 21° C/15° C secondary fluid temperatures using 30% propylene glycol and 35° C air on temperature, split equally between two machines.

The refrigerant mass flow is 0.59 kg/s per compressor x 2 compressors per chiller x 2 chillers; each compressor is using 23.2 kW of power at full load; the design evaporating temperature is 11° C; the design condensing temperature is 50.5° C. The overall chiller energy efficiency ratio (EER) at full load is 3.50, but it

must be remembered that this is a free-cooling chiller, thus the fan energy consumption is relatively high due to the increased air resistance, but the overall annual energy consumption is relatively low due to this same free-cooling. Free-cooling chillers are designed when the need for cooling continues during colder ambient temperatures and that ambient temperature is lower than the return liquid temperature. In this case, there is a large potential to reduce the energy consumption of the liquid chillers by utilising the benefit of low ambient temperatures for substantial proportions of the year.

The system specifications and its capacity are presented in Table 2

Since it is the first application of this new refrigerant in the world, very limited performance and design information is currently available. The new system has performed as expected so far, but better optimisation of the compressor motor / swept volume arrangement could lead to better EER.

Performance:

Since installation this plant has been performing well and no failures have been reported.

The first chillers using the new HFO refrigerants were tried at Waitrose in this supermarket.

This refrigerant has a GWP of 6, i.e. double that of propane (GWP=3.3) but still very low compared with HFCs in general.

The evaporators used with HFO-1234ze should be oversized by around 6% compared to R-134a. There is no discernible difference in the required condensing coil area or air volume. The refrigerant lines need to be generously sized in the gas phase when using HFO-1234ze. The expansion valve sizing is effectively the same as R-134a. The extra cost of the HFO-1234ze compared to R-134a is offset by the lower volume of refrigerant, due to the use of DX evaporators with the HFO-1234ze to deliver the same efficiency as R-134a with flooded evaporator.

All the components have performed as anticipated.

GFC R1234ZE (Waitrose)		KTC11011 TECHNICAL DATA	
MODELL		GFC 2W40/ZE/SP/LLN	
Design data :			
Cooling Capacity	kW	180	
Ambient Temperature	°C	35	
Refrigerant Circuits	n°	2	
Capacity Steps	n°	4	
Noise Level	dB(A) - 10m	50	
Refrigerant	Type	R1234ZE	
Refrigerant Charge (each circuit)	Kg	20.4	
Compressor	Type	Reciprocating	
EER	l	3.5	
Chiller performance :			
Entering Fluid Temp.	°C	21	
Leaving Fluid Temp.	°C	15	
Propylene Glycol	%	30.00	
Water Flow rate	m3/h	27.30	
Water Pressure Drop	KPa	100	
Free cooling mode :			
Total Cooling Capacity	kW	180.00	
Entering Fluid Temp.	°C	21	
Leaving Fluid Temp.	°C	15	
Ambient Temperature	°C	6	
Compressors :			
N° of Compressors	n°	2	
Nominal Power Input (each)	kW	23.20	
Running Current (each)	A	41.17	
Max Current (each)	A	71.40	
Starting Current (each)	A	215.00	
Condenser coil :			
Type	Type	Finned coil	
Pipe material	Type	Copper	
Fins material	Type	Aluminum	
Condenser EC Fan (max 735rpm) :			
Fans Diameter	Mm	800	
Fans Quantity	n°	6	
Total Fans Airflow	m3/h	51200.00	
Total Fans Motor Power Input	kW	5.0	
Evaporator :			
Evaporator Quantity	n°	1	
Type	Type	plate to plate	
Water Holding Volume(total)	LI	163	
Evaporator Expansion device :			
Type	Type	electronic	

Table 2 System specifications and capacity

Spare parts for the system are available. The chillers using this new refrigerant run more efficiently than the hydrocarbon version that is currently used in other stores.

The system uses two 180 kW chillers with a Frascold semi-hermetic compressor supplying chilled water as a condenser medium for the in-store integral cases running on propane (R-290).

A comparison has been done with a same-size store in Canterbury (in south-east England) running identical systems, but using R-290 (propane) instead of HFO-1234ze. The comparison shows a 22% reduction in energy consumption for the HFO system compared to the propane one.

Tests carried out by Frascold with its eight-cylinder reciprocating compressors running on HFO-1234ze indicate a loss of capacity of around 24% compared with R-134a across various application conditions. However, mean power absorbed is almost 27% less, giving an overall COP actually better than R-134a across a range of applications and conditions.

The HFO R-1234ze technology is becoming more available now with more qualified servicing technicians being available. This new refrigerant is non-flammable at 20° C and only slightly flammable at 30° C. A flame will ignite it at 60° C. This refrigerant is treated as a non-toxic, mildly flammable refrigerant.

Cost and Economic Considerations:

The capital cost of the new system is currently approximately 10% more than a propane equivalent at the time of installation, but this cost is expected to go down as production is increased and as the operating characteristics and system design requirements become better understood. The cost of maintenance is the same as for hydrocarbon systems.

Disclaimer

The information presented here is provided by Waitrose. The accuracy of the content and figures is the responsibility of the company and these have not been verified by the CCAC or UNEP.

CASE STUDY

Application of Climate-Friendly Commercial Refrigeration Technologies: H-E-B

Name of the Store/facility:

H-E-B at Mueller

Location:

Austin, Texas, United States

Contact information:

Charlie Wernette, wernette.charlie@heb.com

Type of Facility:

Supermarket, Store Area = 7,711 m²

Refrigerant Used:

Propane Self-Contained Cases

Project Background:

H-E-B has been incorporating sustainability measures into their stores for the past 15 years. As part of their environmental strategy for the H-E-B at Mueller sustainable design test store, H-E-B set a goal to reduce energy and potable water consumption by 50% relative to their 2010 baseline. In addition, H-E-B decided to trial the use of climate-friendly refrigerants.

Prior to the opening of their Mueller store, H-E-B had never used a non-fluorinated refrigerant. With the company's stores located in Texas (United States), and Mexico, H-E-B made a decision not to use a carbon dioxide (CO₂)-based technology, which operates at much higher pressures and therefore is not ideal for use in warmer climates. Inspired by Waitrose—a U.K.-based supermarket chain that began using propane-based refrigeration systems in their stores in 2009—H-E-B approached several equipment manufacturers in the United States about the possibility of implementing a similar type of refrigeration system in their stores. H-E-B ultimately decided to work with Hussmann, and in 2011, the effort to develop self-contained propane units was officially underway. Fig. 1 shows a photo of the store.

New System/Installation:

In total, the H-E-B at Mueller store contains 70 refrigerated cases that have a total cooling capacity of 1,013 MBTUs³. The majority of these cases are self-contained units that use propane (R-290) as the refrigerant. Each condensing unit contains a refrigerant charge size of no more than 150 g, as required by U.S. regulations, adding up to a total of 66.2 kg of propane within the store. The compressors, which pipe the refrigerant directly to the evaporator, are contained within each unit. The vast majority of the propane-refrigerated cases in the store have a door or sliding lid, which minimises energy consumption and allows the refrigerant charge to remain small.

In addition to the propane units, a small number of cases are cooled using a distributed direct expansion refrigeration system. This system, which uses R-404A as the refrigerant, is used to cool select produce cases that are not equipped with a door. These produce cases contain products that are kept wet with an automatic misting system, and therefore cannot be easily equipped with a door. Without a door, it would not have been feasible to keep the refrigerant charge of propane below 150 g; thus, H-E-B reverted to a more traditional refrigeration system to cool these cases.

All of the cases in the store are connected to a water-chilled condenser, which is used to remove heat from the refrigerant after it has removed heat from the refrigerated space. The water-chilled system, which is also used for space cooling and heating, contains 544.3 kg of HFC-134a. It is estimated that roughly 26% of the HFC-134a is used for refrigeration while the rest is used for cooling and heating.



Fig. 1 H-E-B at Mueller, Austin, Texas, United States. Photo courtesy of H-E-B by photographer Ray Briggs



Fig. 2 Deli Meat Cases Photo courtesy of H-E-B by photographer Ray Briggs.

Other Sustainability and Energy Efficiency Measures:

H-E-B at Mueller is the seventh green building certified store by the company. H-E-B designed the store with several energy-saving features as well. LED lights are used throughout the store, both inside the cases and for overhead lighting. The roof is fitted with 169 kW of solar panels that provide part of the store's energy needs.

Performance:

Although the store has only been operational for a few months, the refrigeration system so far is operating as expected. While performance data was not available at the time that this case study was developed, it is projected that the carbon footprint of the store will be reduced by 85% relative to a baseline store. Of the 85% reduction, 58% is attributable to reduced energy use while the remaining 27% is attributable to the direct emissions avoided by using propane as the refrigerant.

From a financial perspective, the store cost more upfront but is expected to save money over time. While capital costs were relatively high, the simple, self-contained design eliminated the need to pay a refrigeration contractor to install the system. Due to the simple design, maintenance costs are also expected to be relatively low. Furthermore, cost savings will be realised through a reduced energy bill. H-E-B anticipates a payback on its investment in energy reduction and advanced refrigeration technology design features.

Challenges and Lessons Learned:

H-E-B has identified a variety of benefits associated with its refrigeration system. First, using propane instead of a traditional HFC refrigerant offers enormous environmental benefits. Propane has a global warming potential (GWP) of three, which is significantly lower than the GWP of traditionally used HFC refrigerants, which can be over 3,000. In addition, the simple 'plug-in'

design, similar to a home refrigerator, is a major benefit. The simple design allowed H-E-B to plug in the self-contained units and hook them up to the water-cooled condenser rather than having to purchase the display cases and refrigeration racks separately and hire a contractor to install the piping network, connect the system, and charge it with refrigerant and oil.

While H-E-B is very happy with the outcome of the store design, it did not come without some challenges. First, the United States Environmental Protection Agency restriction on charge size of 150 g of propane per unit required H-E-B, with the help of Hussmann, to develop a unique system design to accommodate the refrigerant. To compensate for the limited refrigerant charge, the resulting design uses significantly more compressors than a traditional system, which drives up costs. In addition, it was a challenge to overcome the stigma associated with using a flammable refrigerant. The store was required to install extra leak detection and alarm systems prior to receiving approval from the Austin Fire Department to operate.

Even with the challenges that H-E-B faced, they believe that the benefits of this store outweigh the costs; plans are underway to install the novel technology in other H-E-B stores.

Disclaimer

The information presented here is provided by H-E-B. The accuracy of the content and figures is the responsibility of the company and these have not been verified by the CCAC or UNEP.



This booklet is the first of a series of case studies on alternatives to hydrofluorocarbons (HFC). The booklet provides information on energy efficient, zero to low-GWP alternatives to HFCs in the Commercial Refrigeration sector. This information resource is intended to assist relevant decision makers, especially those in developing countries, in selecting the most appropriate climate-friendly alternatives.

For more information, contact;

UNEP DTIE

OzonAction Branch

15, rue de Milan

75441 Paris CEDEX 09, FRANCE

Tel: +33 1 44 37 14 50

Fax: +33 1 44 37 14 74

Email: ozonaction@unep.org

www.unep.fr/ozonaction

Climate and Clean Air Coalition to Reduce Short-Lived Climate Pollutants (CCAC) Secretariat

United Nations Environment Programme
Division of Technology, Industry and Economics

15 rue de Milan

75441 Paris CEDEX 09, FRANCE

Email: ccac_secretariat@unep.org

Telephone: +33 1 44 37 14 50

Fax: +33 1 44 37 14 74

Email: ccac_secretariat@unep.org

www.unep.org/ccac

Publication job number: DTI-1666PA

